

□ HGL140-12

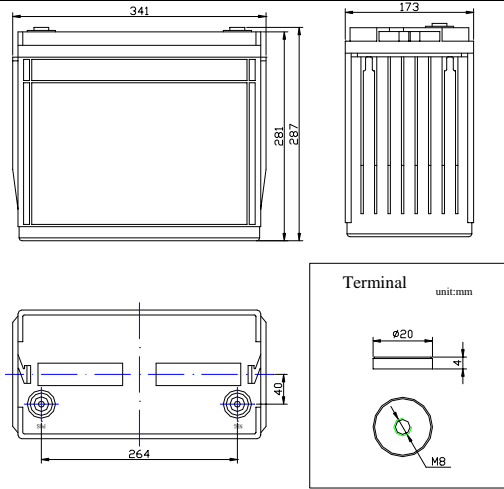

Specifications

Nominal Voltage		12V
Rated Capacity (20 hour rate)		140AH
Dimension	Total Height (with terminals)	287mm(11.30inches)
	Height	281mm(11.06inches)
	Length	341mm(13.43inches)
	Width	173mm(6.81inches)
Weight		Approx.42.5kg (93.5lbs)

Discharge characteristics 77 °F (25 °C)

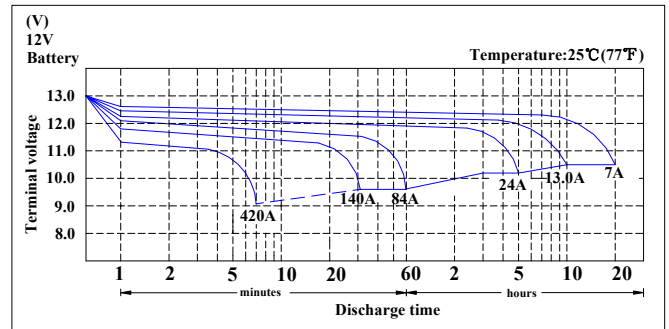

Characteristics

Capacity 77°F (25°C)	20 hour rate (7A to 10.5Volts)	140AH
	10 hour rate (13.0A to 10.5Volts)	130AH
	5 hour rate (24A to 10.2Volts)	119AH
	1 hour rate (84A to 9.6Volts)	84AH
Internal Resistance	Full charged 77°F (25°C)	3.5mΩ
Standard Terminal	M8	
Capacity affected by Temperature (20 hour rate)	104°F (40°C)	102%
	77°F (25°C)	100%
	32°F (0°C)	85%
	5°F (-15°C)	65%
Self-Discharge 77°F (25°C)	Capacity after 3 month storage	91%
	Capacity after 6 month storage	82%
	Capacity after 12 month storage	64%
Max. Discharge Current 77°F (25°C)	1400A (5s)	
Maximum Charge Current(A)	28A	
Charging (Constant Voltage)	Cycle	14.5V~14.9V/77°F (25°C)
	Float	13.6V~13.8V/77°F (25°C)
Temperature compensation coefficient of charging voltage (mV/°C/cell)	Cycle	-4mV/°C/cell
	Float	-3mV/°C/cell

Duration of discharge vs. Discharge current

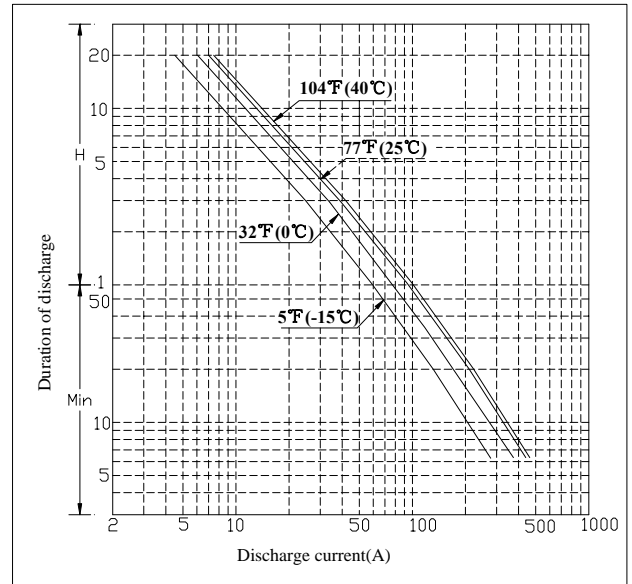

Constant Current Discharge Rating Amperes @ 77°F (25°C)

Cut off voltage V/cell	15M	30M	45M	1H	2H	3H	5H	8H	10H	12H	20H	24H
1.75V	229	138	100	80.6	46.0	34.3	23.3	15.92	13.1	11.2	7.0	5.87

Note The above data are average values, and can be obtained with 3 charge/discharge cycles. These are not minimum values.

FULLRIVER

HGL BATTERIES

This information is generally descriptive only and is not intended to make or imply any representation, guarantee or warranty with respect to any cells and batteries. Cell and battery designs/specification are subject to modification without notice. Contact Fullriver for the latest information.